



**IMPORTANT: FAILURE TO INSTALL AND FINISH THIS PRODUCT IN ACCORDANCE WITH APPLICABLE BUILDING CODES AND JAMES HARDIE WRITTEN APPLICATION INSTRUCTIONS MAY LEAD TO PERSONAL INJURY, AFFECT SYSTEM PERFORMANCE, VIOLATE LOCAL BUILDING CODES, AND VOID THE LIMITED PRODUCT ONLY WARRANTY. BEFORE INSTALLATION, CONFIRM THAT YOU ARE USING THE CORRECT HARDIEZONE INSTRUCTIONS. TO DETERMINE WHICH HARDIEZONE APPLIES TO YOUR LOCATION, VISIT [WWW.HARDIEZONE.COM](http://WWW.HARDIEZONE.COM) OR CALL 1-866-942-7343 (866 9HARDIE)**

### STORAGE & HANDLING

Store flat and keep dry and covered prior to installation (*fig. 1*). Installing siding wet or saturated may result in shrinkage at joints. Protect edges and corners from breakage. James Hardie is not responsible for damage caused by improper storage and handling of the product. When working with Artisan<sup>®</sup> siding and trim products, carry the product on edge. If only one person is carrying the product, hold it in the middle and spread arms apart to better support the product (*fig. 2*). If two people are carrying the product, hold it near each end and on edge (*fig 3*). Do not lift or carry Artisan products flat (*fig 4*).

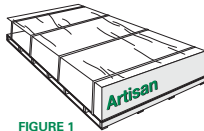

FIGURE 1



FIGURE 2

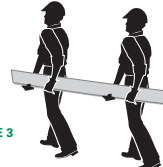

FIGURE 3



FIGURE 4

### CUTTING INSTRUCTIONS - Outdoor

1. Position cutting station so that wind will blow dust away from user and others in working area.
2. Use one of the following methods:
  - a. Better:
    - i. Dust reducing circular saw equipped with a HardieBlade<sup>®</sup> saw blade and HEPA vacuum extraction
  - **NEVER** use a power saw indoors to cut Artisan siding and trim products
  - **NEVER** use a circular saw blade that does not carry the HardieBlade saw blade trademark
  - **NEVER** dry sweep - Use wet suppression or HEPA Vacuum

NIOSH-approved respirators can be used in conjunction with above cutting practices to further reduce dust exposures. Additional exposure information is available at [www.artisanluxury.com](http://www.artisanluxury.com) to help you determine the most appropriate cutting method for your job requirements. If concern still exists about exposure levels or you do not comply with the above practices, you should always consult a qualified industrial hygienist or contact James Hardie for further information.

### INSTALLATION

FIGURE 5

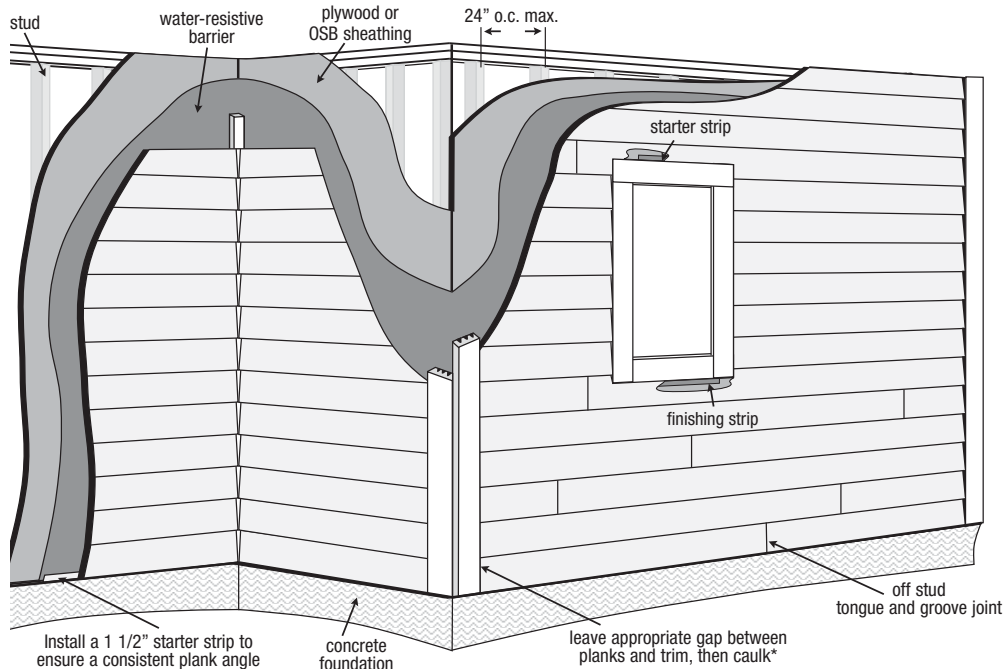

#### Warning: Avoid Breathing Silica Dust

James Hardie<sup>®</sup> products contain respirable crystalline silica, which is known to the State of California to cause cancer and is considered by IARC and NIOSH to be a cause of cancer from some occupational sources. Breathing excessive amounts of respirable silica dust can also cause a disabling and potentially fatal lung disease called silicosis, and has been linked with other diseases. Some studies suggest smoking may increase these risks. During installation or handling: (1) work in outdoor areas with ample ventilation; (2) use fiber cement shears for cutting or, where not feasible, use a Hardieblade<sup>™</sup> saw blade and dust-reducing circular saw attached to a HEPA vacuum; (3) warn others in the immediate area; (4) wear a properly-fitted, NIOSH-approved dust mask or respirator (e.g. N-95) in accordance with applicable government regulations and manufacturer instructions to further limit respirable silica exposures. During clean-up, use HEPA vacuums or wet cleanup methods - never dry sweep. For further information, refer to our installation instructions and Material Safety Data Sheet available at [www.jameshardie.com](http://www.jameshardie.com) or by calling 1-800-9HARDIE (1-800-942-7343). FAILURE TO ADHERE TO OUR WARNINGS, MSDS, AND INSTALLATION INSTRUCTIONS MAY LEAD TO SERIOUS PERSONAL INJURY OR DEATH.

## GENERAL REQUIREMENTS

- Artisan® lap can be installed over braced wood or steel studs spaced a maximum of 24" o.c.. Irregularities in framing and sheathing can mirror through the finished application.
- Artisan lap can also be installed over foam insulation/sheathing up to 1" thick. When using foam insulation/sheathing, avoid over-driving nails (fasteners), which can result in dimpling of the siding due to the compressible nature of the foam insulation/sheathing. Extra caution is necessary if power-driven nails (fasteners) are used for attaching siding over foam insulation/sheathing.
- A water-resistive barrier is required in accordance with local building code requirements. The water-resistive barrier must be appropriately installed with penetration and junction flashing in accordance with local building code requirements. James Hardie will assume no responsibility for water infiltration. James Hardie does manufacture HardieWrap™ Weather Barrier, a non-woven non-perforated housewrap, which complies with building code requirements.
- Adjacent finished grade must slope away from the building in accordance with local building codes - typically a minimum of 6" in the first 10'.
- Do not install James Hardie® products, such that they may remain in contact with standing water.
- Artisan lap butt joints are not required to land on stud. Do not nail within 2" of tongue and groove at end of planks.
- James Hardie recommends cutting tongue or groove off when butting into trim boards (fig. 6).
- Artisan lap requires a trim thickness of 1 1/2" for proper aesthetics.
- Artisan lap may be installed on vertical wall applications only.
- Must follow all clearance and details below.
- For larger projects, including commercial and multi-family projects, where the span of the wall is significant in length, the designer and/or architect should take into consideration the coefficient of thermal expansion and moisture movement of the product in their design. These values can be found in the Technical Bulletin "Expansion Characteristics of James Hardie® Siding Products" at [www.JamesHardie.com](http://www.JamesHardie.com).

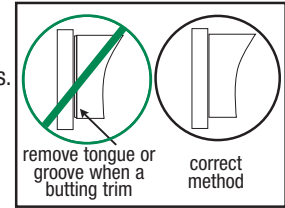

FIGURE 6

## CLEARANCES & DETAILS

- DO NOT use stain on James Hardie® products. James Hardie products must be painted within 180 days for primed product and 90 days for unprimed. 100% acrylic topcoats are recommended. Do not paint when wet. For application rates refer to paint manufacturers specifications. Back-rolling is recommended if the siding is sprayed.
- Install James Hardie® products with a minimum 6" clearance to the finished grade on the exterior of the building or in accordance with local building codes if greater than 6" is required (fig. 7).
- Maintain a 2" minimum clearance between James Hardie® products and paths, steps and driveways (fig. 8 and fig. 9)
- At the juncture of the roof and vertical surfaces, flashing and counterflashing shall be installed per the roofing manufacturer's instructions. Provide a 2" minimum clearance between the roofing and the bottom edge of the siding and trim (fig. 10).
- Maintain a 1/4" clearance between the bottom of James Hardie products and horizontal flashing. Do not caulk gap (fig. 11).
- Maintain a minimum 1" gap between gutter end caps and siding & trim (fig. 12).
- When ending Artisan lap at the bottom of a window or at the top of a wall, a finishing strip similar to a starter strip maybe necessary to achieve a proper plank angle. Also when cutting Artisan lap around doors, windows, or other horizontal trim applications, an additional starter strip maybe necessary to achieve proper plank angle (fig. 13).
- Install kickout flashing at roof-wall junctions (fig. 14).

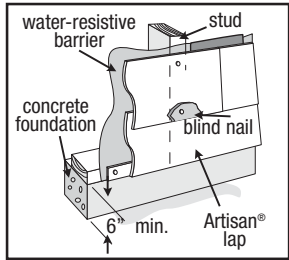

FIGURE 7

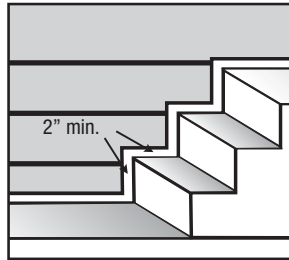

FIGURE 8

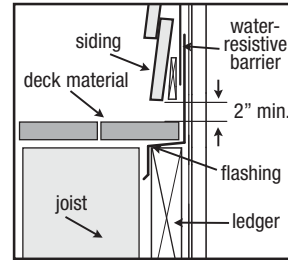

FIGURE 9

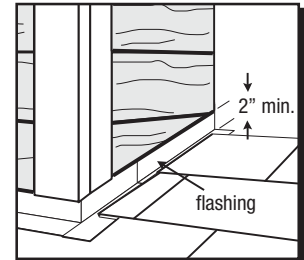

FIGURE 10

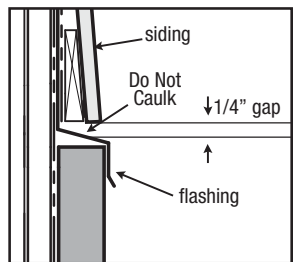

FIGURE 11

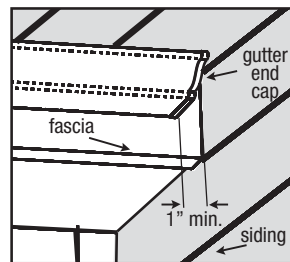

FIGURE 12

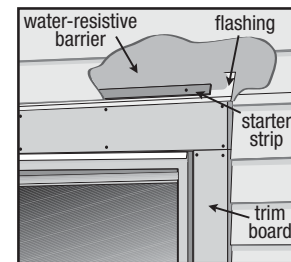

FIGURE 13

## KICKOUT FLASHING

Because of the volume of water that can pour down a sloped roof, one of the most critical flashing details occurs where a roof intersects a sidewall. The roof must be flashed with step flashing. Where the roof terminates, install a kickout to deflect water away from the siding. It is best to install a self-adhering membrane on the wall before the subfascia and trim boards are nailed in place, and then come back to install the kickout. To prevent water from dumping behind the siding and the end of the roof intersection, install a "kickout" of sufficient length and angle to direct the water running down the roof away from the siding (fig. 14).†

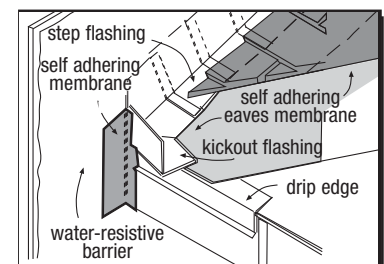

FIGURE 14

† The illustration (figure 14) and associated text was reprinted with permission of THE JOURNAL OF LIGHT CONSTRUCTION. For subscription information visit [www.jlconline.com](http://www.jlconline.com).

## JOINT PLACEMENT & TREATMENT

### JOINT PLACEMENT

Artisan® lap butt joints are not required to land on stud, it is recommended that butt joints be placed 4" off stud (*fig. 15*). Do not nail within 2" of tongue and groove at end of planks.

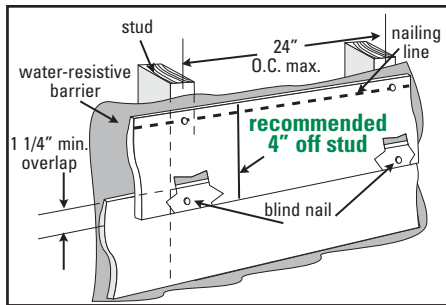

FIGURE 15

### JOINT TREATMENT

Install factory finished tongue and groove edges together at butt joints using Joint Flashing (*fig 16*).

#### Joint Flashing

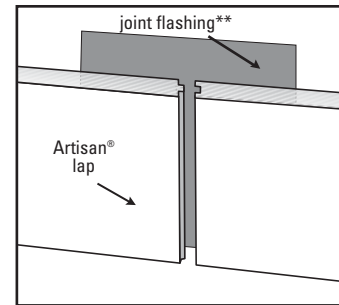

FIGURE 16

## ARTISAN™ ACCENT TRIM

Artisan lap requires a trim thickness of 1 1/2" for proper aesthetics (*figs. 17 & 18*).

- Maintain a minimum 2" clearance between Artisan Accent Trim and roofs, decks, paths, steps and driveways. Maintain a 1/4" clearance between Artisan Accent Trim and horizontal flashing.
- 2 1/2" minimum 16 ga. finish nails may be used to attach Artisan™ Accent Trim to wood frame construction. ET&F or equivalent fasteners or screws may be used to attach Artisan Accent Trim to steel frame construction.
- Fastening instructions are similar for all applications. When using finish nails, position nails no closer than 1/2" from the edges of the trim and for all other fasteners no closer than 3/4". Fasteners must be no closer than 1" from ends of trim and spaced a maximum of 16" o.c. Ensure trim is adequately fastened.  
*Note: James Hardie® recommends installing trim boards so that seams are not visible from the front facing or street curb view (fig.17).*
- Flashing is required over all horizontal protruding and exposed trim.

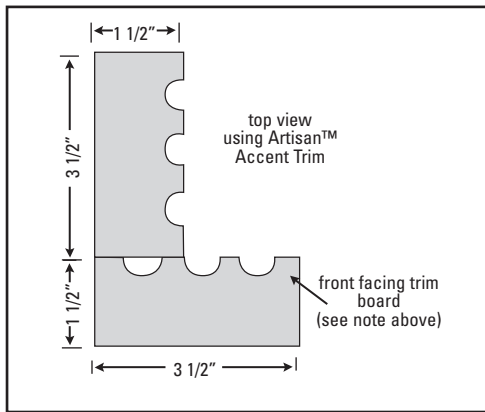

FIGURE 17

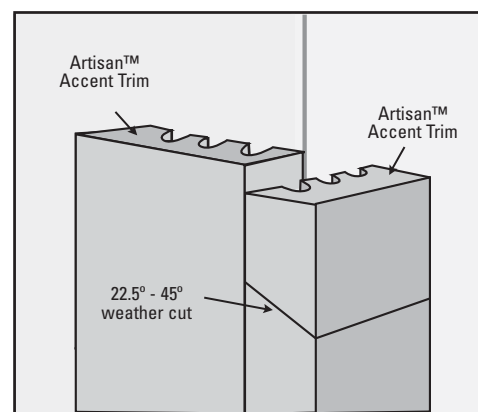

FIGURE 18

Board Width	Pre-built corner	Site Built Corners	Other areas (e.g. window trim, band boards and fascia)
4"	1 nail every 16" to attach boards together + 2 nails every 16" each board	2 nails every 16"	2 nails every 16"
6"	1 nail every 16" to attach boards together + 3 nails every 16" each board	3 nails every 16"	3 nails every 16"

\*\* As required by local building code.

## CONCEALED FASTENING TABS

### For Corners, Band Boards, Windows, and Door Applications:

Artisan® Accent™ Trim boards with Back Grooves can be installed with Flat Tabs (JH sku no. 280154) and Corner Tabs (JH sku no. 280155) which provide concealed fastening. Only Flat and Corner Tabs can be used with Artisan Accent Trim boards to create a concealed fastening. Additional framing may be required to ensure the Flat and Corner Tabs are fastened properly to the structure. Special attention should be paid to the framing when using a sheathing that does not have fastener holding equivalent to OSB or Plywood sheathing.

**Step 1:** Attach Flat Tabs to the back side of the trim with 4 18 ga. 1/2" x 1/4" narrow crown galvanized staples using a pneumatic staple gun. The nail line on the tabs provide a guide for fastening the staples. (Figure 19)

**Step 2:** For wood frame construction, attach the trim to the building with at least 6d siding nails fastened through the Flat Tabs. ET&F or equivalent fasteners may be used to attach the Flat Tabs to steel frame construction. (Figures 20)

Fastener spacing will vary based on application. Refer to specific sections in these instructions for required fastener spacing by application (window, band board, etc.)

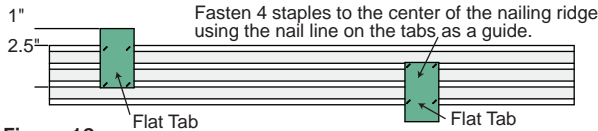

Figure 19

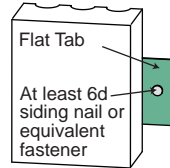

Figure 20

### TRIMMING CORNERS

Artisan® Accent™ Trim boards with back grooves are installed around corners by pre-building the corner off the wall with the Corner Tabs (JH sku no. 280155).

- Attach Corner Tabs to the back side of the trim with 8 18 ga. 1/2" x 1/4" narrow crown galvanized staples using a pneumatic staple gun. Ensure the Corner Tabs are fastened tight and straight to the trim boards. (Figure 21)
- For wood frame construction, attach the trim to the building with 6d siding nails fastened through the Corner Tabs. ET&F or equivalent fasteners may be used to attach the Corner Tabs to steel frame construction. (Figure 22)
- Attach a Corner Tab 1" from each edge and every 3' o.c.
- TIP: Creating a jig for the work station is recommended to ensure the corners are fastened securely and straight. (Figure 24)

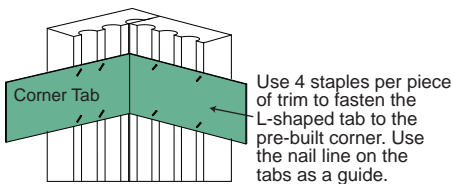

Figure 21

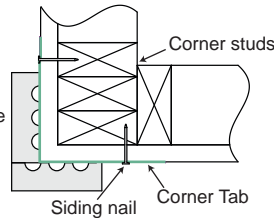

Figure 22

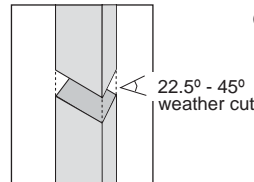

Figure 23

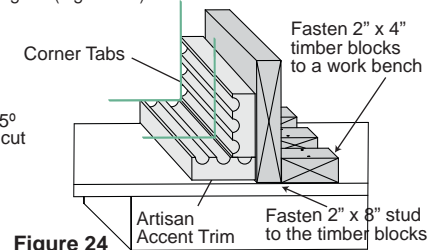

Figure 24

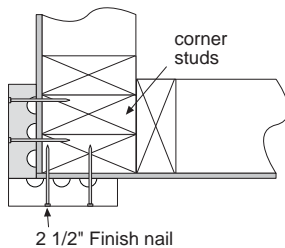

Figure 25

Artisan® Accent™ Trim boards with back grooves can also be installed directly to the building (fig. 25) around corners using 2 1/2" long minimum 16 ga. galvanized finishing nails every 16" o.c.

\*Note: The 5 1/2" trim boards can only be installed directly to the building when used for corners.

## TRIM APPLICATION FOR WINDOWS, DOORS & OTHER OPENINGS

Trim the opening prior to the installation of the siding (Figure 26).

For openings less than 4' in size, place a Flat Tab at the end of each trim board and one tab in the center of each trim. Attach the trim boards and Flat Tabs around the opening as shown in Figures 26 and 27. Use 16 ga. galvanized 2 1/2" finish nails to ensure proper fastening if needed.

For openings greater than 4' in size, place a Flat Tab at the end of each trim board and one tab for each framing member at a maximum of 24" o.c. Attach the trim boards and Flat Tabs around the opening as shown in Figures 26 and 27. Use 16 ga. galvanized 2 1/2" long finish nails to ensure proper fastening if needed.

**Figure 26**

Side trim pieces go to the top of the window.

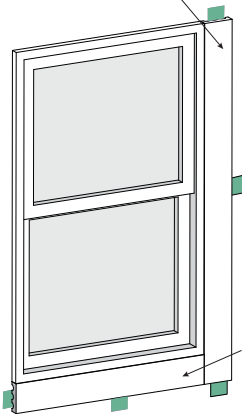

Bottom trim piece is the width of the window.

**Figure 27**

Header piece spans the window including the side trim pieces.

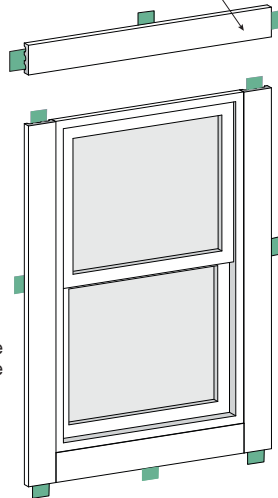

NOTE: Follow your window/door manufacturers installation instructions.

Flashing needs to be tucked under the water resistive barrier and over the Flat Tabs.

Do not caulk between the siding and the flashing.

Water-resistive Barrier 1/4" gap

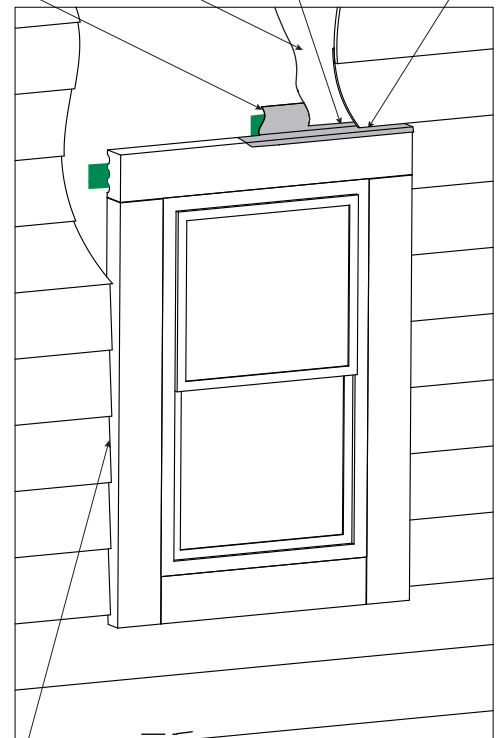

1/8" caulked gap is left between siding and the side trim pieces.

**Figure 28**

## BAND BOARD

A flashing is required over the trim and Flat Tabs. (Figure 29) Terminate ends of the Band Board into Trim or Siding or miter cut the edges of the trim at the corners of the building.

Place a Flat Tab at the end of each trim board and one tab every stud at a maximum of 24" o.c. The Flat Tabs should be attached to the trim in an alternating pattern to the top and bottom of the band board (Figure 30 and 31). Use 16 ga. galvanized 2 1/2" long finish nails to ensure proper fastening if needed.

Fasten 4 staples to the center of the nailing ridge

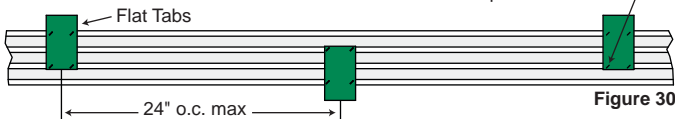

**Figure 30**

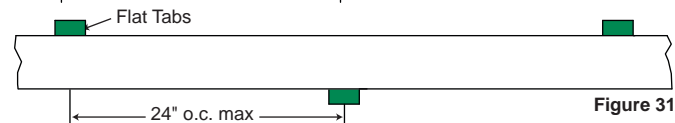
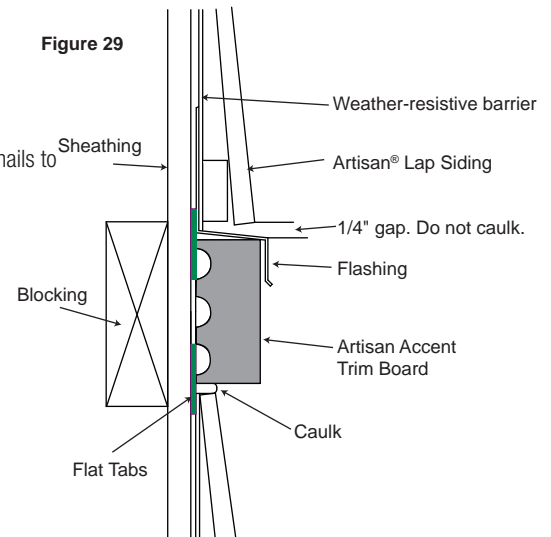

**Figure 31**

**Figure 32**

<p><b>Flush</b></p> <p>Siding nail attaches tab to the wall.</p>	<p><b>Flat and Corner Tabs</b></p> <p>Do not drive nails.</p>	<p>Only use staples to fasten Flat and Corner Tabs to the trim boards.</p>
--	---	--

**Figure 29**



\* Refer to your paint manufacturer for washing and recoating requirements related to paint performance.

## GENERAL FASTENING REQUIREMENTS

Fasteners must be corrosion resistant, galvanized, or stainless steel. Electro-galvanized are acceptable but may exhibit premature corrosion. James Hardie recommends the use of quality, hot-dipped galvanized nails. James Hardie is not responsible for the corrosion resistance of fasteners. Stainless steel fasteners are recommended when installing James Hardie® products.

### PNEUMATIC FASTENING

James Hardie products can be hand nailed or fastened with a pneumatic tool. Pneumatic fastening is highly recommended. Set air pressure so that the fastener is driven snug with the surface of the siding. A flush mount attachment on the pneumatic tool is recommended. This will help control the depth the nail is driven. If setting the nail depth proves difficult, choose a setting that under drives the nail. (Drive under driven nails snug with a smooth faced hammer - Does not apply for installation to steel framing).

- Consult applicable code compliance report for correct fasteners type and placement to achieve specified design wind loads.
- NOTE: Published wind loads may not be applicable to all areas where Local Building Codes have specific jurisdiction. Consult James Hardie Technical Services if you are unsure of applicable compliance documentation.
- Drive fasteners perpendicular to siding and framing.
- Fastener heads should fit snug against siding (no air space) (fig. A).
- Do not over-drive fastener heads or drive at an angle.
- If fastener is countersunk, caulk fasteners hole and add a nail (fig. B)
- For wood framing, under driven fasteners should be hit flush to the plank with a hammer (For steel framing, remove and replace nail).
- Do not use aluminum fasteners, staples, or clipped head nails on Artisan Lap or when face nailing Artisan Accent Trim.
- Use the nailing line provided on the board for proper nail placement.

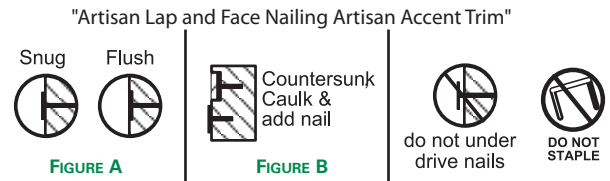

## FASTENER REQUIREMENTS

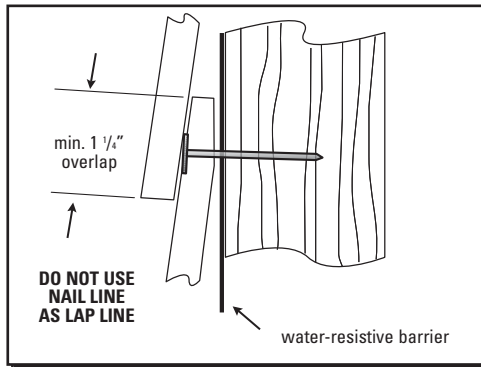

FIGURE 33

### BLIND NAILING (required)

#### Wood Framing

- Siding nail (0.09" shank x 0.221" HD x 2 1/4" long)

#### Steel Framing

- Ribbed Bugle Head screw (No. 8-18 x 0.323" HD x 1 5/8" long)

FIGURE 34

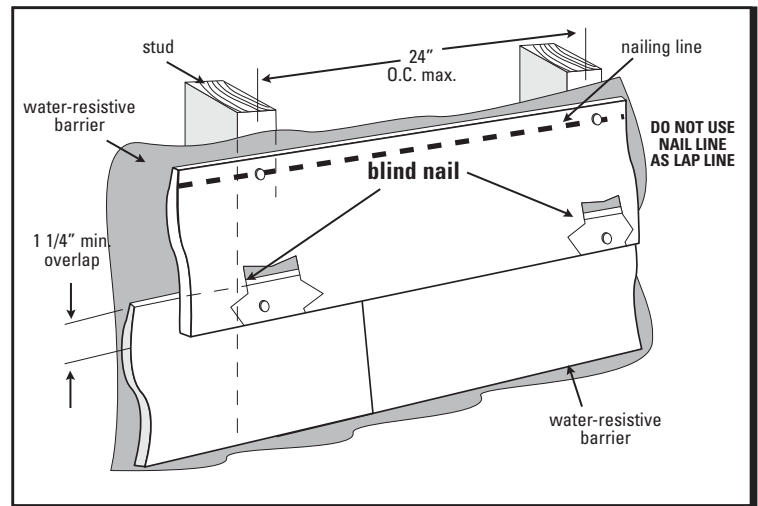

### Proper nail placement

- Do not nail within 2" of tongue and groove at end of planks.
- Use the nailing line provided on the board for proper nail placement.

## CAULKING & PAINTING

For best results use an Elastomeric Joint Sealant complying with ASTM C920 Grade NS, Class 25 or higher or a Latex Joint Sealant complying with ASTM C834. Caulking/Sealant must be applied in accordance with the caulking/sealant manufacturer's written instructions or ASTM C1193.

James Hardie products must be painted within 180 days for primed product and 90 days for unprimed.

100% acrylic topcoats are recommended. Do not paint when wet. For application rates refer to paint manufacturers specifications. Back-rolling is recommended if the siding is sprayed. James Hardie recommends the use of flat paint on Artisan

DO NOT use stain on James Hardie® products. James Hardie products must be painted within 180 days for primed product and 90 days for unprimed. 100% acrylic topcoats are recommended. Do not paint when wet. For application rates refer to paint manufacturers specifications. Back-rolling is recommended if the siding is sprayed.

### CUT EDGE TREATMENT

Caulk, paint or prime all field cut edges.

\* Refer to your paint manufacturer for washing and recoating requirements related to paint performance.

## CARE & MAINTENANCE

As a guide, it is recommended that normal maintenance tasks shall include but not be limited to:

- Washing down the exterior surfaces every 6 to 12 months with a garden hose or low pressure water spray to remove dirt and debris.\*
- Re-applying of exterior finishes.\*
- Maintaining the exterior envelope and connections including joints, penetrations, flashings, and sealants (caulking) that may provide a means of moisture entry beyond the exterior cladding.
- Cleaning out gutters, blocked pipes, and overflows as required.
- Pruning back vegetation that is touching the building. Clearance between the siding and shrubs is recommended.
- Ensuring required external ground clearances and drainage slopes are maintained.

**Warning:** High pressure water blasts (e.g. pressure washers) and sand blasting will damage the surface of fiber cement. James Hardie does not recommend these methods of cleaning. Low pressure water spray, or a medium bristle (nonmetal) brush are more suitable for cleaning fiber cement products.

## COVERAGE CHART/ESTIMATING GUIDE

Number of 12' planks, Includes 5% waste factor.

Coverage Area Less Openings 1 SQ = (100sq. ft.)	Artisan® lap width			
	Plank Width Exposure	5 1/4 4	7 1/4 6	8 1/4 7
1		27	18	15
2		53	35	30
3		79	53	45
4		105	70	60
5		132	88	75
6		158	105	90
7		184	123	105
8		210	140	120
9		237	158	135
10		263	175	150
11		289	193	165
12		315	210	180
13		342	228	195
14		368	245	210
15		394	263	225
16		420	280	240
17		447	298	255
18		473	315	270
19		499	333	285
20		525	350	300

This coverage chart is meant as a guide. Actual usage is subject to variables such as building design. James Hardie does not assume responsibility for over or under ordering of product.

**RECOGNITION:** Artisan® lap complies ASTM C1186 in so doing meets the Fiber-Cement Siding code requirements in the 2006 International Building Code® Section 1404.10, 1405.15, and 1405.17.2; and the 2006 International Residential Code® for One- and Two-Family Dwellings Table R70.4 and section R703.10.2. Supplementary code compliance details are found the *Artisan® lap Code Compliance Sheet*.

**RECOGNITION:** RECOGNITION: HardieTrim® boards may be installed as an equal alternative to conventional trim permitted for use in; the 1997 Uniform Building Code, Section 601.5.5; the 1997 Standard Building Code, Section 1404.1; the 1999 BOCA National Building Code, Section 1407.2.2; 2003 International Building Code, Section 1402.1, the 2003 International Residence Code for One - and Two - Family - Dwellings, Section R703.1. the 2003 International Residence Code for One - and Two - Family - Dwellings, Section R703.1. and the 1998 International One-and -Two -Family Dwelling Code,Section 601.1.

